

In-Line Document Support

Customer Needs:

Place to hold source materials directly in front of the monitor screen, provide better viewing angles for the user and help to eliminate neck, back, and posture stress.

User Requirements:

- Direct vertical orientation to improve visual ergonomics
- Allows for varying focal length distances
- Easy to make angle adjustments
- Able to hold legal or letter-size paper; one or more sheets

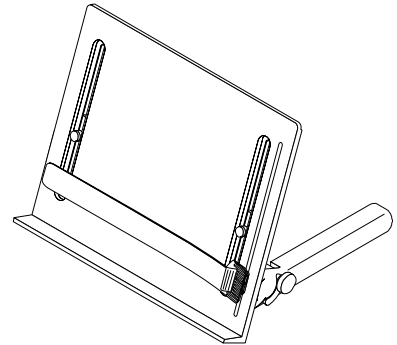

Product Features

Style Numbers:

CDFIS14 – 14" In-Line Document Holder

- Color: Black
- Construction: Injection-molded plastic
- Application: Fits either around the monitor or adjacent; uses minimal desktop space
- Warranty: 10 years
- Height adjustable easel with an 8" range.
- Adjustable for use with a split-top worksurface.
- Adjustable focal length to fit preferred distances.
- Width adjustable across the entire front for easy access to the CPU.

For further information, please go to the Details website details-worktools.com
or call 800.833.0411

P.O. Box 1967 / CD-5E Grand Rapids, MI 49501-1967
©2010 Steelcase Inc. All rights reserved. 5/10