

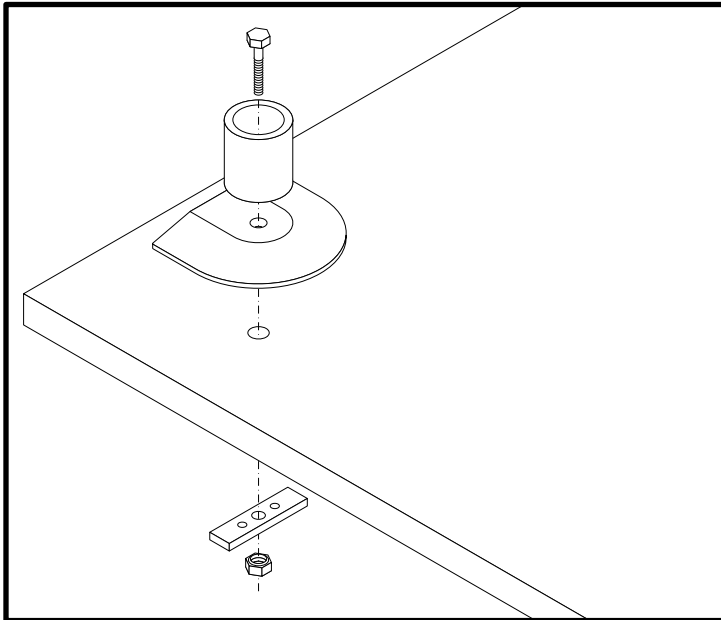

Installation Instructions

Through Mount
Flat Panel
Arm Bracket
CFSPTM

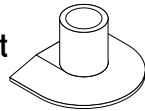

- 1** Do not attach an arm to a desk less than 1" thick. Drill a 3/8" diameter hole through your worksurface to accommodate the hex head bolt provided.
- 2** Align the metal mount column over the mount plate.
- 3** Insert the 3/8"-16 x 2" 1/2" long silver hex head bolt down through the metal mount column and through a 3/8" hole drilled through your worksurface.
- 4** Slide the metal spacer onto the bolt and screw the lock nut onto the bolt.
- 5** Tighten the metal spacer against bottom of the worksurface.

For a better day at work.™

details®

A STEELCASE COMPANY

www.details-worktools.com

P.O. Box 1967 Grand Rapids, MI 49501-1967

All rights reserved. Printed in U.S.A. 1/05