

# Hanging Brackets

## Customer Needs:

A cost-effective method of managing files on the desktop. Users do not like to file “active” projects into drawers – “out of sight, out of mind” is a real fear in the workplace. A mechanism is needed to allow quick access physically and visually.

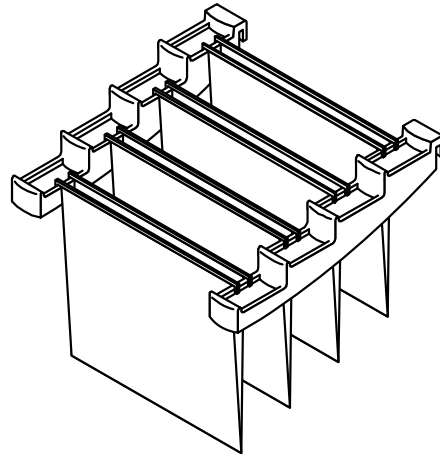

## Product Features

Style Numbers:

WHB – Hanging Brackets

- Size: W1-1/2” x H1-1/4” x D9-3/4”
- Color: Amber, Arctic White, Black, Frost, or Rain.
- Construction:
  - o Translucent: Injection-molded engineering resin for quality and durability.
  - o Opaque (Arctic White and Black): Injection-molded ABS plastic for quality and durability.
- Application: Slatwall, SlatRail panel-mounted, and SlatRail stanchion-mounted except for bottom step.
- Maximum Weight Load: 5 lbs. per step (20 lbs. total).
- Warranty: 10 years.
- Holds large capacity of Pendaflex®-type folders.
- Open areas have been designed so product will not attract dust.
- Allows user to have immediate visual access to all active work.
- Dense paper/project management without using any desk space.
- Product has four steps to allow user to see all work on the brackets.
- Work is not “out of sight, out of mind”
- Product can hold hanging folders, Office in a File, or any other type of product designed to fit into a pedestal.
- Excellent for the project-oriented user who must manage many activities simultaneously.
- Easy to file and easy to retrieve. No wasted time searching through jammed pedestal drawers.
- If mounted under a binder bin, this product needs a minimum 6” clearance from top step to access files in the rear.
- Product has a “stop” at each step to prevent files from dropping to a lower level.
- Product is sold only as a pair.

**For further information, please go to the Details website [details-worktools.com](http://details-worktools.com)  
or call 800.833.0411**

P.O. Box 1967 / CD-5E Grand Rapids, MI 49501-1967  
©2009 Steelcase Inc. All rights reserved. 4/10