

# Letter Tray

## Customer Needs:

- A low-cost, flexible method of filing paper.
- Need to get documents off worksurface and organized.
- Must have easy access (physically and visually).

## Product Features

### Style Numbers:

- WLTS – 10" Letter Tray – Portrait
- WLT12L – 12" Letter Tray - Landscape
- WLG15L – 15" Legal Tray – Landscape

### Size:

- WLTS – W10" x H2-1/2" x D12-1/2"
- WLT12L – W12-1/2" x H2-1/2" x D10"
- WLG15L – W15-1/2" x H2-1/2" x D10"

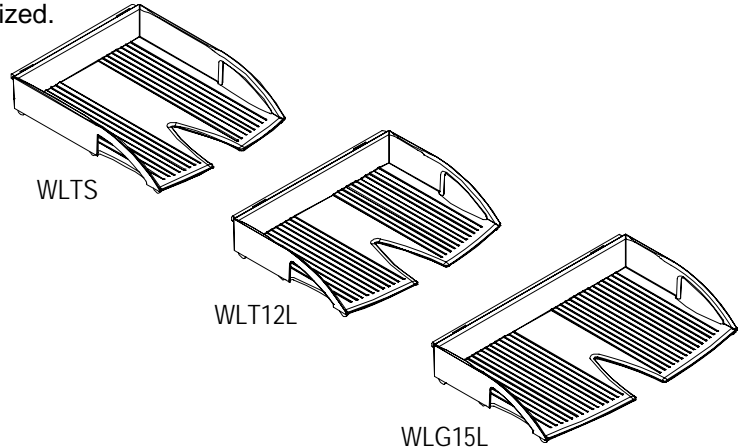

- Color: Amber, Arctic White, Black, Frost or Rain.
- Construction:
  - o Translucent: Injection-molded engineering resin for quality and durability.
  - o Opaque (Arctic White and Black): Injection-molded ABS plastic for quality and durability.
- Application: Slatwall, SlatRail, Freestanding, Binder Bin
- Maximum Weight Load: 7 lbs. per tray (or 2" of material)
- Warranty: 10 years
- Will stack four-high on SlatRail or freestanding with no additional parts. Feet interlock to provide alignment support. No costly stacking bracket to purchase.
- Can stack infinitely on Slatwall (note: trays do not interlock when installed on Slatwall).
- Will accommodate A4, letter and legal-size paper, FedEx® envelopes.
- May be used in multiples in binder bin to provide dense paper organization in a closed storage area.
- Efficient labeling can be achieved by using the Work Tag. As tray function changes, so can the tag.
- Easy access to horizontal filing.
- Low-cost product for tight budgets/bid situations.
- Handles allow product to be repositioned easily.
- Finger grip area provided for easy paper retrieval.

For further information, please go to the Details website [details-worktools.com](http://details-worktools.com)  
or call 800.833.0411

P.O. Box 1967 / CD-5E Grand Rapids, MI 49501-1967  
©2009 Steelcase Inc. All rights reserved. 4/10