

Lift & Lock Keyboard Mechanisms

Customer Needs:

A ready adjustable keyboard support mechanism that is easy to operate, will work with a wide variety of support platforms and provide exceptional stability

Product Features

Style Numbers:

- L523 – 5" arm mechanism with 23" Track
- L726 – 7" arm mechanism with 26" Track

Size:

- L523 – W4" x H2¼" x D15½"
- L726 – W4" x H2¼" x D17½"

Weight:

- L523 – 8 lbs.
- L726 – 9 lbs.

- Color: Black
- Construction: Powder coated steel.
- Application: Use in straight or corner workstation configurations with all Details keyboard platforms
- Warranty: 10 years.
- Ideal for intensive computer user or multi-user workstation.
- Applicable to either wood or metal surfaces.
- L523 Mechanism height range: 8.3" travel range, 2.5" above the track to 5.8" below the track.
- L726 Mechanism height range: 10.8" travel range, 3.0 above the track to 7.8 below the track.
- Degrees of tilt angle possible: +/- 15 degrees.
- Rear swivel has 360 degree range.
- Product meets or exceeds all applicable ANSI/BIFMA test standards.
- Mechanisms are 98% Recyclable

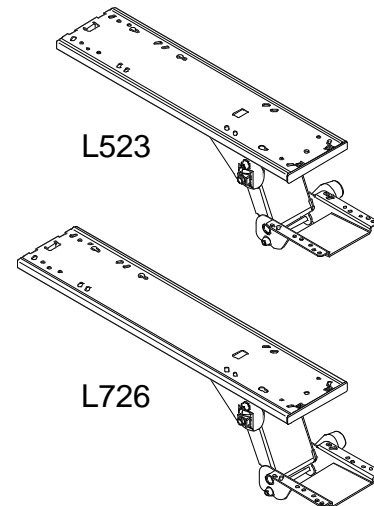

For further information, please go to the Details website details-worktools.com
or call 800.833.0411

P.O. Box 1967 / CD-5E Grand Rapids, MI 49501-1967
©2010 Steelcase Inc. All rights reserved. 5/10