

Medical Glove Box

Customer Needs:

Cost-effective way to house any standard size box of exam gloves. With this flexible Slatwall or SlatRail mounted holder, exam gloves are reachable and easily dispensed. Gloves are kept within view without being obtrusive or taking up space on a worksurface.

Product Features

Style Numbers:

HCGB – Medical Glove Box

- Size: W10" x H3" x D3¼"
- Color: Pewter
- Construction: Powder-coated steel
- Application: Slatwall, SlatRail
- Warranty: 10 Years
- Holds any standard size glove box: small, medium, large, and extra large.

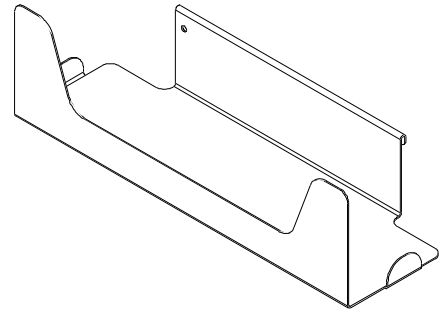

For further information, please go to the Details website details-worktools.com
or call 800.833.0411

P.O. Box 1967 / CD-5E Grand Rapids, MI 49501-1967
©2009 Steelcase Inc. All rights reserved. 4/10