

PaperFlo[®] Manager

Customer Needs:

An effective way to organize the various types of paper used within a workstation.

User Requirements:

- To organize paper within a user's workstation and move it off the horizontal worksurface.
- Can be customized to the individual user's requirements.
- Simplicity of rearrangement.
- Can be placed at convenient heights above the worksurface.
- Ideal for mail sorting or managing multiple projects.

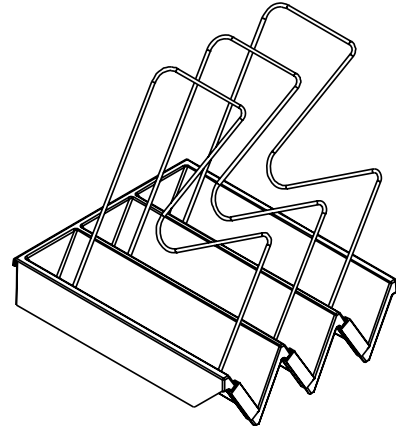

Product Features

Style Numbers:

WPFS – PaperFlo[®] Manager

- Size: W9.75" x H9.75" x D12"
- Weight: 2 lbs.
- Color: Base: Amber, Arctic White, Black, Frost or Rain
- Construction: Sturdy plastic base with see-through metal wire dividers.
 - Translucent: Injection-molded engineered resin for quality and durability.
 - Opaque (Arctic White or Black): Injection-molded ABS plastic for quality and durability.
- Application: Slatwall or SlatRail
- Documents readily visible in the stored position.
- Can be mounted to face either right or left.
- Each PaperFlo Manager comes with subject identification tags.
- Comes with three slots.

For further information, please go to the Details website details-worktools.com
or call 800.833.0411

P.O. Box 1967 / CD-5E Grand Rapids, MI 49501-1967
©2011 Steelcase Inc. All rights reserved. 3/11