

SOTO™ Display Shelves

Customer Needs:

Ideal for managing active and anticipated work. Designed to reclaim worksurface space, support the behavior of feathering reference materials and holding them at an angle for easy viewing with clean lines and a quiet aesthetic.

Product Features

Style Numbers:

DDS245 24"W shelf with 5"H stanchions
DDS248 24"W shelf with 8"H stanchions

- Shelf Color: Arctic White or Platinum
- Stanchion/Bracket Color: Platinum
- Construction:
 - Shelf: 16 ga. sheetmetal
 - Stanchions: 7 ga. sheetmetal
 - Brackets: die cast zinc alloy
- Application: Attaches to SOTO Rail and c:scape rail architecture
- Maximum Weight Load: 36 lbs. of material per shelf
- Warranty: 10 years
- Accommodates letter, legal and A4 materials
- SOTO rail mounting/c:scape rail mounting hardware included
- Channel accommodates SOTO Utility Box (DSUB)
- Two height options allow for space under the 8" Shelf to accommodate other SOTO boxes and shelves
- 5" high stanchions allow for 3-1/8" between worksurface and bottom of shelf
- 8" high stanchions allow for 5-5/8" between worksurface and bottom of shelf

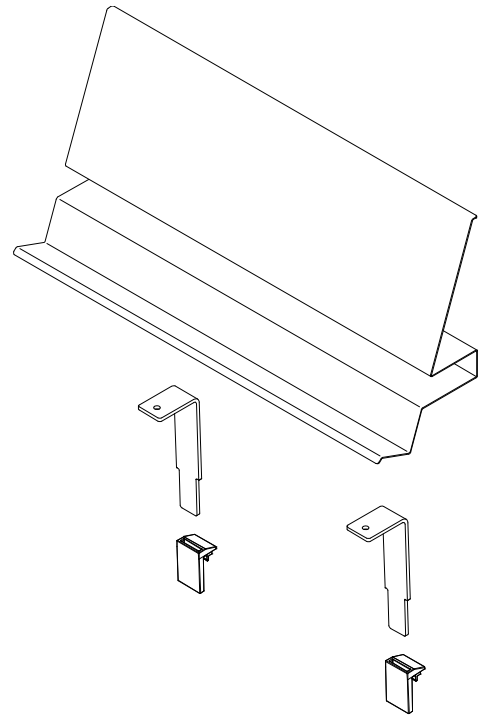

For further information, please go to the Details website details-worktools.com
or call 800.833.0411

P.O. Box 1967 / CD-5E Grand Rapids, MI 49501-1967
©2009 Steelcase Inc. All rights reserved. 01/10

For a better day at work.®

details

A Steelcase Company