

SOTO™ Letter Box

Customer Needs:

The Landscape Letter Box is ideal for supporting the behavior of piling work and managing active and anticipated work.

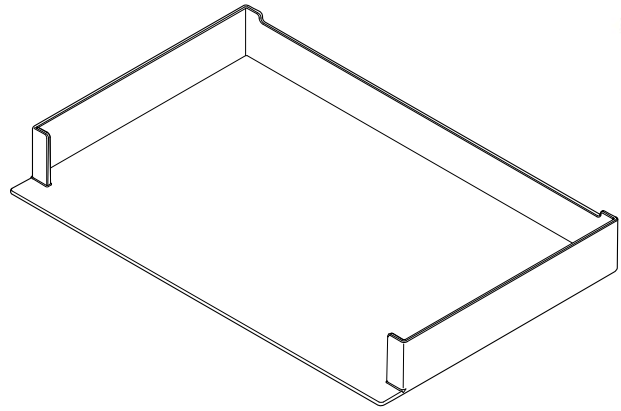

Product Features

Style Number: DSLLB

- Colors: Arctic White and Black
- Construction: ABS plastic
- Weight: 0.8 lb.
- Dimensions: W13-3/4" x H2" x D9-7/8"
- Application: Freestanding
- Warranty: 10 years
- Utilize on SOTO 10" Shelf (DSS2410) or worksurface
- Fits in c:scape furniture drawers and on shelves
- Can be used individually or stacked horizontally
- Boxes interlock when stacked horizontally
- Open front allows user to easily view materials while boxes are stacked
- Accommodates letter size paper or files
- High gloss finish

For further information, please go to the Details website details-worktools.com
or call 800.833.0411

P.O. Box 1967 / CD-5E Grand Rapids, MI 49501-1967
©2009 Steelcase Inc. All rights reserved. 01/10

For a better day at work.®

details

A Steelcase Company