

SOTO™ Rail

Customer Needs:

Any length Rail supports many SOTO shelf and worktool combinations with clean lines and a quiet aesthetic while keeping items up off the worksurface.

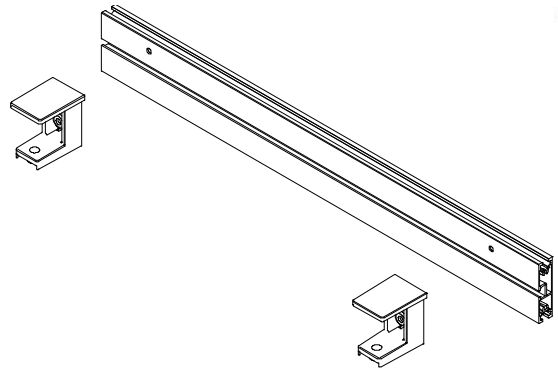

Product Features

Style Numbers:

DSR28	28" wide rail
DSR34	34" wide rail
DSR40	40" wide rail
DSR46	46" wide rail
DSR52	52" wide rail
DSR58	58" wide rail
DSR64	64" wide rail

Style Numbers for use with Tour Furniture System from Turnstone only:

DSRT52	52" wide rail
DSRT58	58" wide rail
DSRT64	64" wide rail

- Color: Platinum
- Construction:
 - Rail: extruded aluminum
 - Clamps: die cast aluminum
- Application: Clamps to freestanding worksurfaces or materials up to 2" thick. Not applicable for glass surfaces
- Maximum Weight Load: 2 lbs per lineal inch (multiple rail length x2 for max load)
- Warranty: 10 years
- 1" clearance between worksurface and rail for cable management
- Flush with top of worksurface
- Allow for 2" installed behind worksurface for rail mount. Allow for 3-3/4" to install rail.
- Clamp mounting brackets included
- Each clamp requires a 2" footprint above the worksurface
- Each clamp requires a 3-1/4" clearance under the worksurface
- Rubber feet under clamps ensure a tight fit without marring the worksurface
- Worksurface must be able to support 2.1 lbs/inch of width for stability
- Each rail is 3-1/2" high and 1" deep.

For further information, please go to the Details website details-worktools.com or call 800.833.0411

P.O. Box 1967 / CD-5E Grand Rapids, MI 49501-1967
©2009 Steelcase Inc. All rights reserved. 01/10

For a better day at work.®

details

A Steelcase Company