

# SOTO™ Shelves

## Customer Needs:

Ideal for managing active and anticipated work. Designed to reclaim worksurface space, support the behavior of piling, and provide a place for personal objects or technology with clean lines and a quiet aesthetic.

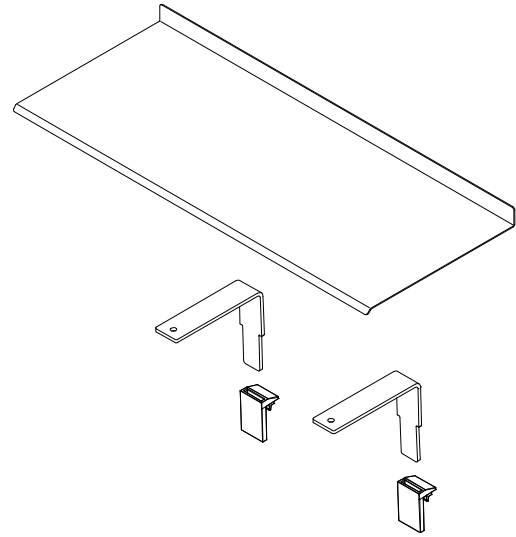

## Product Features

### Style Numbers:

DSS2410	24"W x 10"D shelf
DSS246	24"W x 6"D shelf
DSS363	36"W x 3"D shelf

- Shelf Color: Arctic White or Platinum
- Stanchion/Bracket Color: Platinum
- Construction:
  - Shelf: 16 ga. sheetmetal
  - Stanchions: 7 ga. sheetmetal
  - Brackets: die cast zinc alloy
- Application: Attaches to SOTO Rail and c:scape rail architecture
- Maximum Weight Load:
  - 3" Shelf holds 22 lbs. of material per shelf
  - 6" Shelf holds 30 lbs. of material per shelf
  - 10" Shelf holds 40 lbs. of material per shelf
- Warranty: 10 years
- Supports many configurations of SOTO boxes
  - 3"D shelf accommodates Tool Box (DSTB) and Utility Box (DSUB)
  - 6"D shelf accommodates Storage Box Set of Three (DSSB)
  - 10"D shelf accommodates Pile Box (DSSPB), Diagonal File Box (DSDFB) and Personal Box (DSPB), as well as stacked Pile and Personal Boxes
- SOTO rail mounting/c:scape rail mounting hardware included
- Shelves are able to accommodate boxes on top or underneath
- Can be mounted underneath a SOTO Display Shelf with 8" high stanchions (DDS248)
- All SOTO shelves allow for 2-7/8" between worksurface and bottom of shelf

For further information, please go to the Details website [details-worktools.com](http://details-worktools.com)  
or call 800.833.0411

P.O. Box 1967 / CD-5E Grand Rapids, MI 49501-1967  
©2010 Steelcase Inc. All rights reserved. 11/10

For a better day at work.®

details

A Steelcase Company