



156658 Rev B

Installation Instructions

Needed for installation:

- Power drill
- 1/8" drill bit
- Phillips head bit

Processor Sling
CPRSL

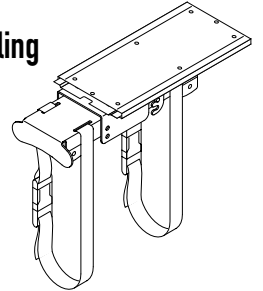

1 Pre-drill holes with 1/8" drill bit. Attach track.

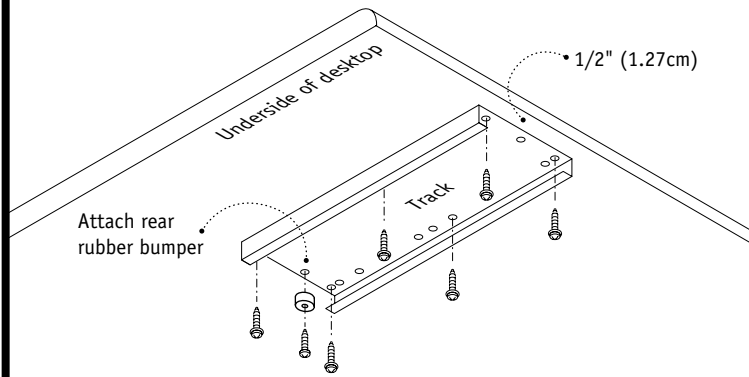

2

a Insert processor. Snap buckles together.

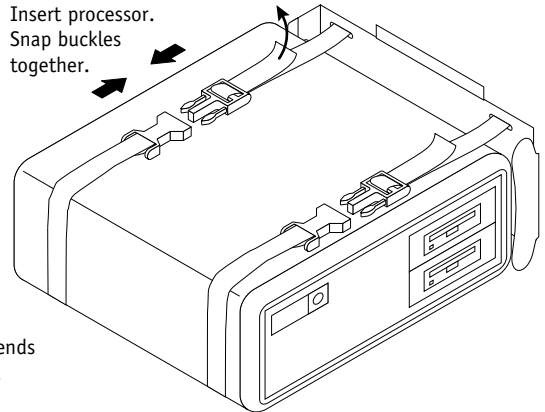

b Pull strap ends to tighten.

3 Slide Processor Sling into track.

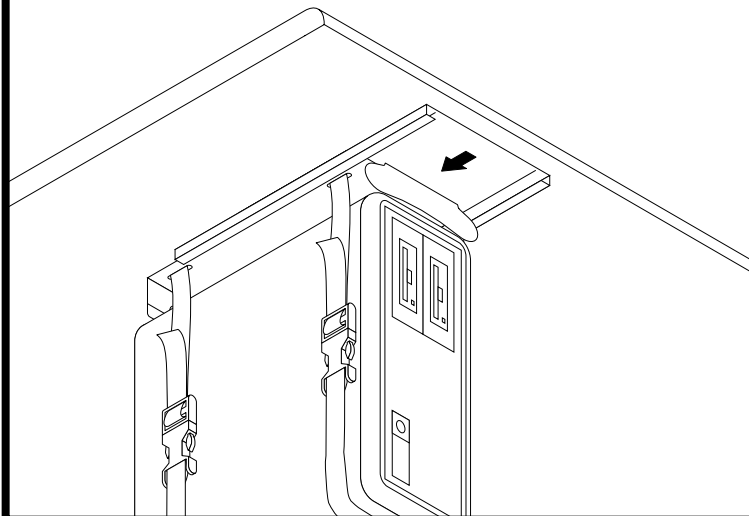

4 Pre-drill holes. Attach front cap.

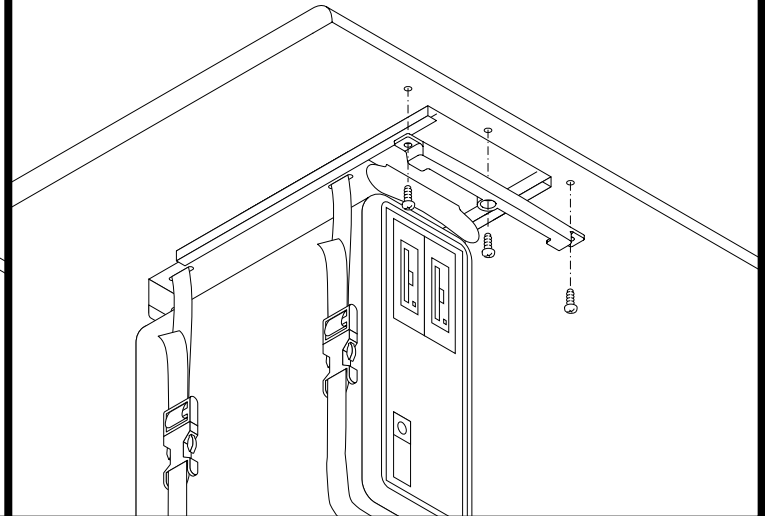

For a better day at work.™

details®

A STEELCASE COMPANY

www.details-worktools.com
P.O. Box 1967 Grand Rapids, MI 49501-1967
All rights reserved. Printed in U.S.A. 1/05